

Molecular diversity of *Symbiodinium* spp. within six coral species in Larak Island, the Persian Gulf

Dehghani H.¹; Ghavam Mostafavi P.^{1*}; Fatemi S.M.R.¹;
Fallah Mehrabadi J.²

Received: October 2015

Accepted: January 2016

Abstract

Reef-building coral harbor communities of photosynthetic taxa of the genus *Symbiodinium* (zooxanthellae). The genus *Symbiodinium* is currently classified into nine genetic clades (A–I). Various corals harbor different *Symbiodinium* clades; some show specificity to a single strain. Coral and their zooxanthellae are sensitive to environmental stresses. In the Persian Gulf, coral reefs are subject to harsh environmental conditions including extreme temperatures and high salinity. This is the first study to use clade specific primers to clarify the diversity of *Symbiodinium* in each coral species of Larak Island. For this purpose six coral species were collected at two different locations in Larak Island. After DNA extraction, PCR amplification was performed using clade specific primers. The results showed that multiple *Symbiodinium* clades are hosted by most coral species. In addition, among thirteen obtained *Symbiodinium* sequences, the frequency of either tree clades, A, C and D was almost the same. Corals species may contain different clades of *Symbiodinium* depending on the region and on the tolerance characteristics of each clade. Thus, knowledge of zooxanthellae diversity associated with scleractinian can contribute to a better understanding of the sensitivity of corals to environmental conditions.

Keywords: Persian Gulf, *Symbiodinium*, Clade A, Clade C, Clade D.

1-Department of Marine Biology, Science and Research Branch, Islamic Azad University, Tehran, Iran

2-Department of Biology, School of Basic Science, University of Qom, Qom, Iran

*Corresponding author's Email: gh.mostafavi@gmail.com

Introduction

Reef corals are hosts to a group of exceptionally diverse dinoflagellate symbionts of the genus *Symbiodinium* (commonly referred to as zooxanthellae) (Pochon and Gates, 2010). The high productivity and diversity of coral reefs is largely due to this mutualistic symbiosis (Silverstein *et al.*, 2012). The *Symbiodinium* transports newly fixed organic carbon to the coral and, in return, receive inorganic waste metabolites from host respiration and an environment free from predators (Davy, 2012).

Symbiodinium are morphologically cryptic and most species are morphologically similar (Baker, 2003). Therefore, their identification must be done on molecular methods. It has been established that there are at least nine major clades of this dinoflagellate genus (Pochon and Gates, 2010). Numerous sub-clades and types have also been identified within each *Symbiodinium* clade, most commonly using the internal transcribed spacer-2 (ITS-2) marker (LaJeunesse, 2002).

Scleractinian coral and their endosymbiont are sensitive to environmental stresses that include salinity (Reimer, 1971), high temperatures (Hoegh-Guldberg and Smith, 1989), low temperatures (Steen and Muscatine, 1987), ultraviolet radiation (Gleason and Wellington, 1993) and turbidity (Trench, 1986). The physiological responses of *Symbiodinium* vary greatly among phylogenetic types; for example, among

the known clades, *Symbiodinium* clade D has a higher thermal tolerance than other clades, and clade D increases the resistance of corals that harbor them to elevated sea surface temperatures (Rowan, 2004; Berkelmans and van Oppen, 2006). The thermal and physiological flexibility of *Symbiodinium* may provide mechanisms for scleractinian corals to survive under unfavorable conditions (Berkelmans and van Oppen, 2006).

The previous studies have shown that corals associate with different *Symbiodinium* clades or types depending on local environmental conditions (Baker, 2003). The Persian Gulf, located in the northwest of the Indian Ocean, is known as one of the most extreme environments for coral reefs with high temperature fluctuations, high salinity, high turbidity and low depth (Sheppard *et al.*, 1992; Baker, 2004). Research conducted on northern Persian Gulf zooxanthellae since 2005 demonstrates the occurrence of *Symbiodinium* clades D, C and A in the shallow waters of the world's hottest sea (Mostafavi *et al.*, 2005, 2014; Shahhosseiny *et al.*, 2011). The present study aims to investigate the diversity of *Symbiodinium* in coral species of Larak Island, one of the seventeen islands in the northern Persian Gulf. Individual colonies can associate with several genetically distinct symbionts simultaneously. Corals of the same species may vary in their symbionts depending on environmental characteristics (van

Oppen *et al.*, 2001). Therefore, the results of this survey will provide a valuable insight to the survival of Iranian coral reefs in the unfavorable environment of the Persian Gulf.

Material and methods

Sampling

Colonies of six species of scleractinian corals, *Favia pallida* (DANA, 1846); *Leptastrea transversa* (Klunzinger, 1879); *Psammocora contigua* (Esper, 1794); *Stylophora pistillata* (Esper, 1797); *Pocillopora damicornis* (Linnaeus, 1758) and *Acropora*

downingi (Wallace, 1999) were collected from two sites, S1 (latitude 26° 53' 22.39" N, longitude 56° 21' 10.44" E) and S2 (latitude 26° 52' 33.61"N, longitude 56° 20' 9.84" E), at depths 3 m (S1) and 6 m (S2) off Larak Island (Fig. 1) during March 2013. After collection, samples were preserved in DMSO buffer (20% DMSO, 0.25M EDTA, saturated with NaCl, pH=8) and transferred to the marine biology laboratory in the Islamic Azad University, Science and Research Branch.

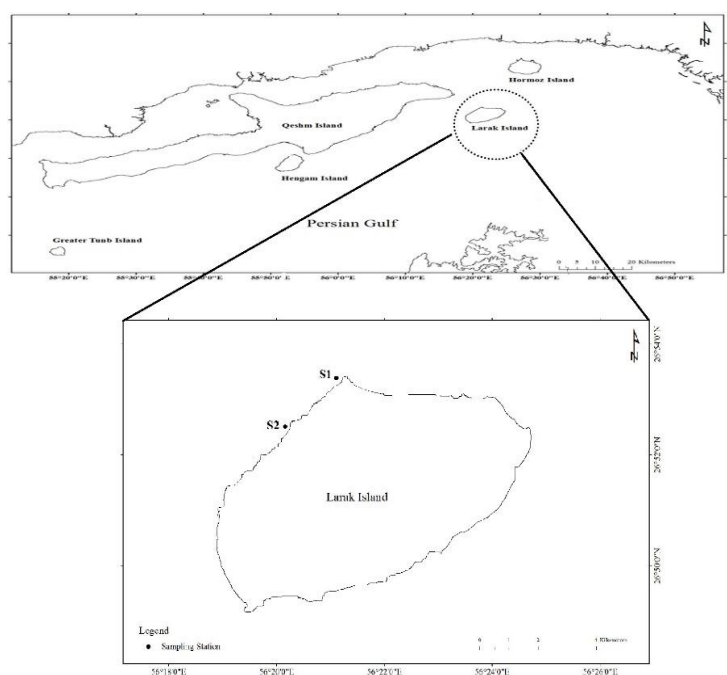

Figure 1: Map of the Larak Island showing the position of the sampling locations.

DNA extraction PCR amplification and sequencing

DNA was extracted using cetyl trimethylammonium bromide (CTAB)/Chloroform method (Baker, 1999). Polymerase Chain Reactions (PCR) assays were performed using three clade-specific primer sets

targeting the ITS1-5.8S-ITS2 (for clade A) (Correa *et al.*, 2009), domain 2 of the LSU (for clade D) (Correa *et al.*, 2009) and partial ITS 1 (for clade C) (Ulstrup and van Oppen, 2003) of the nuclear rDNA of *Symbiodinium*. Each PCR reaction comprised, 1.5 mM MgCl₂, 0.2 mM dNTPs Mix, 10 pmol

of each primer, 0.3 U *Taq* DNA polymerase and 1 ng DNA Template for a total volume of 25 μ L. Amplification was performed using a Bio-Rad PCR Thermal Cycler with the following thermal profile: 30 cycles of 30s at 94°C, 30 s at 58°C, 56°C and 60°C (for clade A, C and D, respectively), 30s at 72°C and a final extension for 5 min at 72°C. The PCR products were analyzed by electrophoresis in 1.5% agarose gels. Thirteen PCR products obtained from this study were directly sequenced to confirm that the specific primers only recognize the target of interest. Finally, this was approved by constructing a phylogenetic tree based on sequences of each molecular marker.

Phylogenetic analyses

Sequences obtained from this study were deposited in a GenBank and their accession numbers are shown in Table 1. The new nucleotide sequences obtained during the present study were aligned with sequences available from the Genbank using the software CLUSTALW (Thompson *et al.*, 1994). Three alignment datasets were generated (for clade A, C and D). The alignment datasets were analyzed using maximum likelihood (ML), maximum parsimony (MP) and Bayesian methods.

Table1: Host species, *Symbiodinium* clade and GenBank accession numbers.

Coral species	<i>Symbiodinium</i> clade	GenBank accession numbers
<i>Favia pallida</i>	Clade A	KT069226
<i>Leptastrea transversa</i>	Clade A	KT069227
<i>Stylophora pistillata</i>	Clade A	KT069228
<i>Pocillopora damicornis</i>	Clade A	KT069229
<i>Favia pallida</i>	Clade C	KT069230
<i>Leptastrea transversa</i>	Clade C	KT069231
<i>Psammocora contigua</i>	Clade C	KT069232
<i>Stylophora pistillata</i>	Clade C	KT069233
<i>Pocillopora damicornis</i>	Clade C	KT069234
<i>Favia pallida</i>	Clade D	KT069235
<i>Leptastrea transversa</i>	Clade D	KT069236
<i>Psammocora contigua</i>	Clade D	KT069237
<i>Acropora downingi</i>	Clade D	KT069238

The most appropriate model selection for ML and Bayesian analyses was performed using Akaike Information Criterion (AIC) in MODELTEST 2.3 (Nylander, 2004). The general time-reversible model (Rodriguez *et al.*, 1990) with gamma parameter (GTR+G)

gave the best fit to the data (clade A, C and D). ML and MP analyses were conducted using the MEGA6 (Tamura *et al.*, 2013) and PAUP beta version 4.0b10 (Swofford, 2002) respectively. ML and MP clades were assessed with 1,000 bootstrap replicates. The

Bayesian analysis was implemented in MrBayes 2.3 (Ronquist and Huelsenbeck, 2003) and was based on the model selected by MODELTEST above. Starting from random trees, four Markov chains (with one cold and three heated chains) were run simultaneously to sample trees using the Markov Chain Monte Carlo (MCMC) principle which approximates the posterior probability (PP) of trees. After the burn-in phase (the first 5 million generations was discarded), every 100th tree out of 20^6 was considered. The phylogenetic trees generated in all analyses were visualized using TREEVIEW (Page, 1996).

Results

The results showed that there are three clades of *Symbiodinium* from Larak Island; clade A, C and D. *Symbiodinium* sequences belonging to clade A were identified from *F. pallida*, *L. transversa*, *S. pistillata* and *P. damicornis*, clade C from *F. pallida*, *L. transversa*, *S. pistillata*, *P. damicornis*, *P. contigua* and clade D from *F. pallida*, *L. transversa*, *P. contigua* and *A. downingi*.

Figs. 2, 3 and 4 show the ML phylogenetic tree for the aligned sequences. As the tree topologies were similar in all analyses, the bootstrap values for MP and Bayesian posterior probabilities are shown on the ML tree (Figs. 2, 3 and 4).

The phylogenetic tree of *Symbiodinium* clade A sequences is shown in Fig. 2. The clade A

Symbiodinium from four coral species strongly clustered (ML= 91%, MP=90%, PP=0.9) with subclade A1 *Symbiodinium* that is hosted by *Cassiopea xamachana* in Jamaica (AF427466), *Acropora* sp. in Japan (AB849873-AB849875) and *Zoanthus sansibaricus* in South Africa (KM032592).

The phylogenetic tree of *Symbiodinium* clade C ITS -1 sequence is shown in Fig. 3. The clade C *Symbiodinium* sequences from five coral species together with previously reported sequences, including some sequences from zoantharians in Madagascar (KM032585), Singapore (EU333738) and South Africa (KM032562) formed a highly supported monophyly (ML= 99%, MP=100%, PP=1.0) within the *Symbiodinium* clade C radiation.

Phylogenetic results of large subunit ribosomal (LSU) RNA gene analyses are shown in Fig. 4. In the tree of clade D, all D-matching sequences from four coral species grouped with five previously reported sequences that belonged to clade D AB778761, AB778758, AB778750 from nudibranch and KF672733, KF030947 from stony corals in a well-supported monophyly (ML= 100%, MP=100%, PP=1.0).

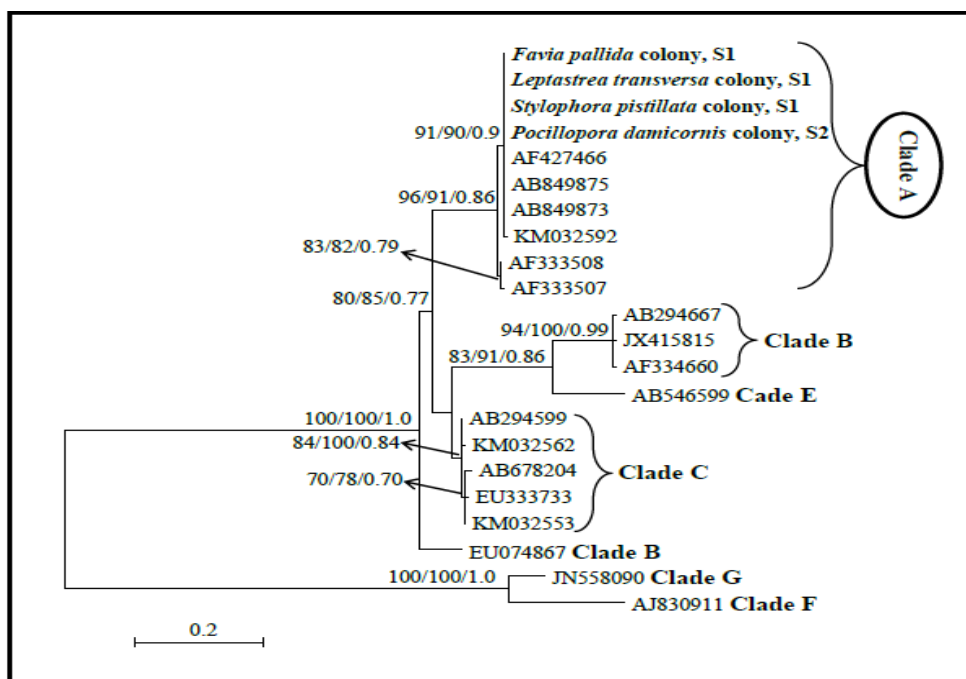

Figure 2: Maximum likelihood tree of ITS1-5.8S-ITS2 sequences for clade A. Values at branches represent maximum likelihood bootstrap percentages from 1000 trees/ maximum parsimony bootstrap percentages from 1000 trees /Bayesian posterior probabilities.

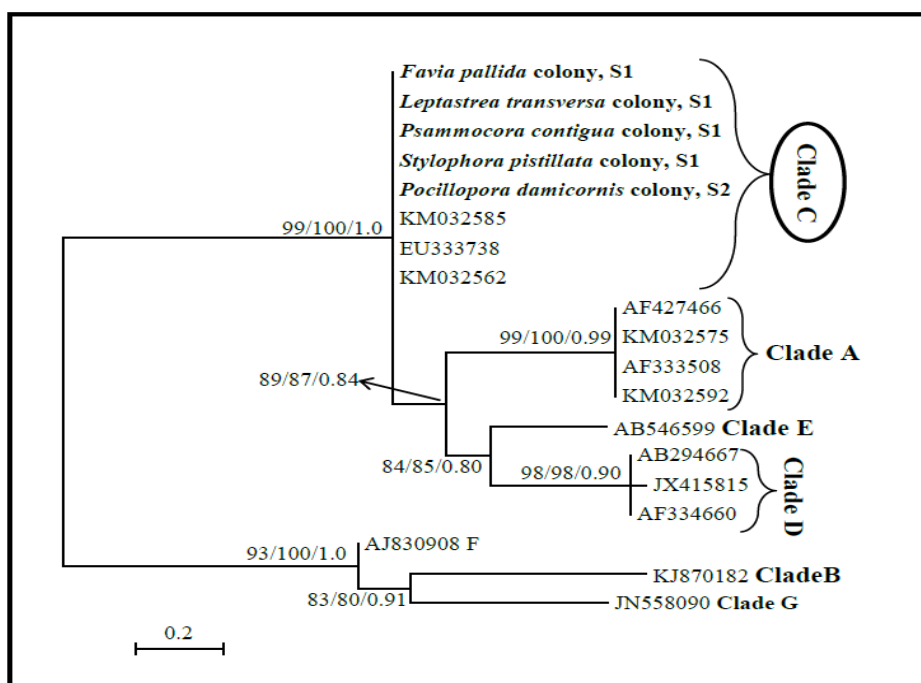

Figure 3: Maximum likelihood tree of partial ITS 1 for clade C. Values at branches represent maximum likelihood bootstrap percentages from 1000 trees/ maximum parsimony bootstrap percentages from 1000 trees /Bayesian posterior probabilities.

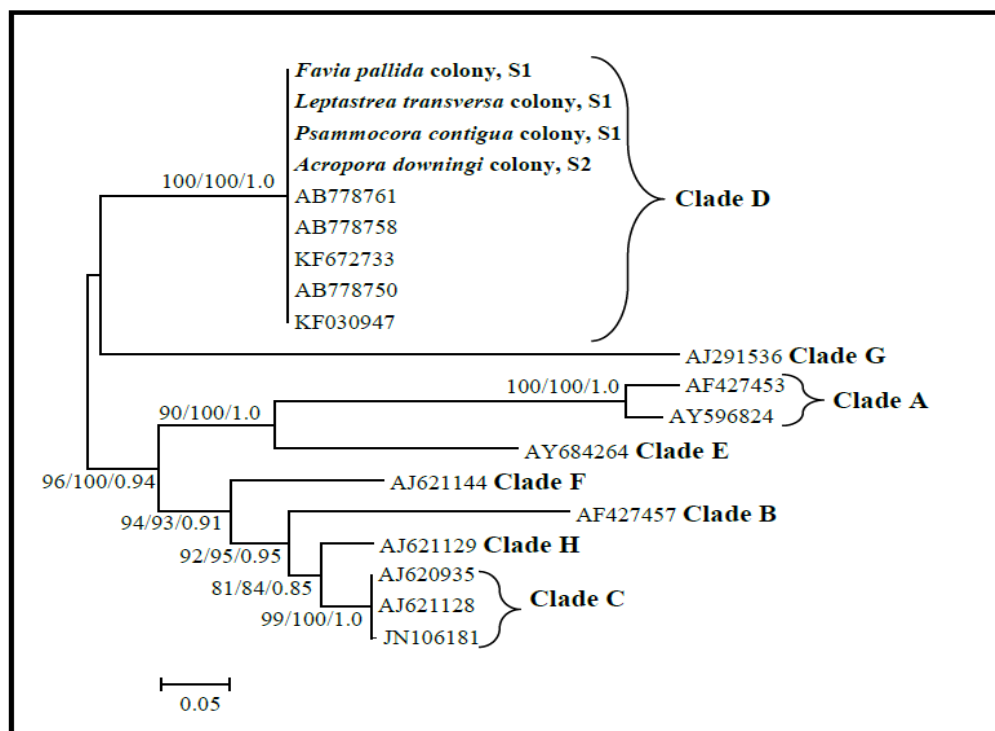

Figure 4: Maximum likelihood tree of LSU for clade D. Values at branches represent maximum likelihood bootstrap percentages from 1000 trees/ maximum parsimony bootstrap percentages from 1000 trees /Bayesian posterior probabilities

Discussion

In coral reefs off Larak Island, colonies of *F. pallida* and *L. transversa*, hosted *Symbiodinium* clades A, C and D simultaneously, *S. pistillata* and *P. damicornis* were associated with both *Symbiodinium* clades A and C, *P. contigua* harbored clade D and also clade C. Although the majority of coral species contained different *Symbiodinium* clades; *A. downingi* show specificity to single *Symbiodinium* strain, clade D.

Several studies have shown that most coral colonies harbor multiple clade of *Symbiodinium* (Berkelmans and van Oppen, 2006; Mieog *et al.*, 2007). Therefore, in the present study PCR was performed with clade-specific primers. It appears that the occurrence

of *Symbiodinium* clade in coral species is depends on a combination of factors such as symbiont availability (van Oppen *et al.*, 2001). Previous research conducted on the zooxanthellae of the Persian Gulf have demonstrated the occurrence of *Symbiodinium* clades D, C and A in this region (Baker *et al.*, 2004; Mostafavi *et al.*, 2007, 2013; Shahhosseiny *et al.*, 2011; Hume *et al.*, 2015). Consequently, three pairs of primers belonging to clade A, C and D were used to amplify the selected marker in these clades.

Most previous studies on the zooxanthellae of the Persian Gulf have shown that clade D of *Symbiodinium*, is the most abundant of all coral symbionts (Baker *et al.*, 2004;

Mostafavi *et al.*, 2005, 2014; Shahhosseiny *et al.*, 2011).

Globally, clade D is common to corals from environments with high temperature and salinity (Fabricius *et al.*, 2004), warm temperature and low light (Ulstrup and van Oppen, 2003) and high turbidity (van Oppen *et al.*, 2001; Chen *et al.*, 2003). Therefore, it has been concluded that the predominance of clade D in the Persian Gulf is due to the unfavorable condition of this region (Mostafavi *et al.*, 2007). However, among the coral species collected in this study, clade D was not the most abundant symbiont. The results of the present study have shown that four colonies of the six species harbored clade A and/or D, while five colonies of six specimens were associated with clade C. The clade C dominance reported here agrees with another study of *Symbiodinium* from the southern Persian Gulf (Hume *et al.*, 2015).

Although Clade C was more dominant *Symbiodinium*, other clades including A and D were commonly detected in corals off Larak Island.

Clade A of *Symbiodinium* have been found in corals inhabiting very shallow high-irradiance waters (Rowan *et al.*, 1997). It is known that only clade A of *Symbiodinium* are capable of producing considerable amounts of mycosporine-like amino acids (MAAs) (Banaszak *et al.*, 2000), compounds that help to protect against damage from UV radiation (Neale *et al.*, 1998). On the other hand, clade D of *Symbiodinium* is

thermally tolerant and increases the resistance of corals that harbor them to elevated sea surface temperature. Furthermore, the thermally resistance of clade C has been reported previously (Mostafavi *et al.*, 2013). It can therefore be concluded that the simultaneous presence of these clades in common coral species of the Persian Gulf may impart some protection from future stresses that lead to coral bleaching.

Acknowledgements

The authors would like to thank Dr. Atoosa Noori Koupaei for laboratory assistance during this research.

References

- Baker, A.C., 1999.** The symbiosis ecology of reef-building corals. PhD thesis, University of Miami.
- Baker, A.C., 2003.** Flexibility and specificity in coral–algal symbiosis: diversity, ecology and biogeography of *Symbiodinium*. *Annual Review of Ecology, Evolution, and Systematics*, 34, 661-689.
- Baker, A.C., Starger, C.J., McClanahan, T.R. and Glynn, P.W., 2004.** Corals' adaptive response to climate change. *Nature*, 430, 741-742.
- Banaszak, A.T., Lajeunesse, T.C. and Trench, R.K., 2000.** The synthesis of mycosporine-like amino acids (MAAs) by cultured symbiotic dinoflagellates. *Journal of Experimental Marine Biology and Ecology*, 249, 219-233.

- Berkelmans, R.W. and Oppen, M.J.H., 2006.** The role of zooxanthellae in the thermal tolerance of corals: a 'nugget of hope' for coral reefs in an era of climate change. *Proceedings of the Royal Society B: Biological Sciences*, 273, 2305-2312.
- Chen, C.A., Lam, K.K., Nakano, Y. and Tsai, W.S., 2003.** Stable association of a stress-tolerant zooxanthellae, *Symbiodinium* clade D, with the low-temperate tolerant coral *Oulastrea crispata*, (Scleractinia; Faviidae) in subtropical nonreefal coral communities. *Zoological Studies*, 42, 540-550.
- Correa, A.M.S., McDonald, M.D. and Baker, A.C., 2009.** Development of clade-specific *Symbiodinium* primers for quantitative PCR (qPCR) and their application to detecting heat tolerant symbionts in Caribbean corals. *Marine Biology*, 156, 2403-2411.
- Davy, S.K., Allemand, D. and Weis, V.M., 2012.** Cell biology of cnidarian-dinoflagellate symbiosis. *Microbiology and Molecular Biology Reviews*, 76(2), 229-261.
- Fabricius, K.E., Mieog, J.C., Colin, P.L., Idip, D. and van Oppen, J.H., 2004.** Identity and diversity of coral endosymbionts (zooxanthellae) from three Palaun reefs with contrasting bleaching temperature and shading histories. *Molecular Ecology*, 13, 2445-2458
- Gleason, D.F. and Wellington, G.M., 1993.** Ultraviolet radiation and coral bleaching. *Nature*, 365, 836-838.
- Hoegh-Guldberg, O. and Smith, J., 1989.** The effect of sudden changes in temperature, light and salinity on the population density and export of zooxanthellae from the reef corals *Stylophora pistillata* Esper and *Seriatopora hystrix* Dana. *Journal of Experimental Marine Biology and Ecology*, 129, 279-303.
- Hume, B.C.C., D'Angelo, C., Smith, E.G., Stevens, J.R., Burt, J. and Wiedenmann, J., 2015.** *Symbiodinium thermophilum* sp. nov., a thermotolerant symbiotic alga prevalent in corals of the world's hottest sea, the Persian/Arabian Gulf. *Scientific Report*, 5(8562), 1-8.
- LaJeunesse, T.C., 2002.** Diversity and community structure of symbiotic dinoflagellates from Caribbean coral reefs. *Marine Biology*, 141, 387-400.
- Mieog, J.C., van Oppen, N.E., Cantin, W.T. and Stam, J.L., Olsen, 2007.** Real-time PCR reveals a high incidence of *Symbiodinium* clade D at low levels in four scleractinian corals across the Great Barrier Reef: implications for symbiont shuffling. *Coral Reefs*, 26, 449-457.
- Mostafavi, P.G., Fatemi, M.R., Shahhosseiny, M.H., Hoegh-Guldberg, O. and Loh, W.K.W., 2005.** Predominance of clade D *Symbiodinium* in shallow water reef-building corals off Kish and Larak

- Islands (Persian Gulf, Iran). *Marine Biology*, 153, 25-34.
- Mostafavi, P.G., Ashrafi, M.G. and Dehghani, H., 2013.** Are symbiotic algae in corals in northern parts of the Persian Gulf resistant to thermal stress? *Aquatic Ecosystem Health and Management*, 16, 177-182.
- Neale, P.J., Banaszak, A.T. and Jarriel, C.R., 1998.** Ultraviolet sunscreens in *Gymnodinium sanguineum* (Dinophyceae): mycosporine-like amino acids protect against inhibition of photosynthesis. *Journal of Phycology*, 34, 928-938.
- Nylander, J., 2004.** MrModeltest v2. Program distributed by the author. Evolutionary Biology Centre. Uppsala University.
- Page, R.D.M., 1996.** TREEVIEW: an application to display phylogenetic trees on personal computers. *Computer Applications in the Biosciences*, 12, 357-358.
- Pochon, X. and Gates, R.D., 2010.** A new *Symbiodinium* clade (Dinophyceae) from soritid foraminifera in Hawai'i. *Molecular Phylogenetics and Evolution*, 56, 492-497.
- Reimer, A.A., 1971.** Observations on the relationship between several species of tropical zoanthids (Zoanthidae, Coelenterata) and their zooxanthellae. *Journal of Experimental Marine Biology and Ecology*, 7, 207-217.
- Rodriguez, F., Oliver, J., Marin, A. and Medina, J.R., 1990.** The general stochastic model of nucleotide substitution. *Journal of Theoretical Biology*, 142, 485-501.
- Ronquist, F. and Huelsenbeck, J.P., 2003.** MrBayes 3: Bayesian phylogenetic inference under mixed models. *Bioinformatics*, 19, 1572-1574.
- Rowan, R., Knowlton, N., Baker, A. and Jara, J., 1997.** Landscape ecology of algal symbionts creates variation in episodes of coral bleaching. *Nature*, 388, 265-269.
- Rowan, R., 2004.** Thermal adaptation in reef coral symbionts. *Nature*, 430, 742.
- Shahhosseiny, M.H., Mostafavi, P.G., Fatemi, S.M.R. and Karimi, E., 2011.** Clade identification of symbiotic zooxanthellae of dominant scleractinian coral species of intertidal pools in Hengam Island. *African Journal of Biotechnology*, 10(9), 1502-1506.
- Sheppard, C.R.C., Price, A.R.G. and Roberts, C.J., 1992.** Marine ecology of the Arabian area. Patterns and processes in extreme tropical environments. Academic Press, London.
- Silverstein, R.N., Correa, A.M.S. and Baker, A.C., 2012.** Specificity is rarely absolute in coral-algal symbiosis: implications for coral response to climate change. *Proceedings of the Royal Society B: Biological Sciences*, 279, 2609-2618.
- Steen, R.G. and Muscatine, L., 1987.** Low temperature evoke rapid exocytosis symbiotic algae by a sea

- anemone. *The Biological Bulletin*, 172, 246-263.
- Swofford, D., 2002.** Phylogenetic analysis using parsimony (PAUP), version 4.0 b10. Sinauer Associates, Sunderland.
- Tamura, K., Stecher, G., Peterson, D., Filipski, A. and Kumar, S., 2013.** MEGA6: molecular evolutionary genetics analysis. version 6.0. *Molecular Biology and Evolution*, 30, 2725-2729.
- Thompson, J.D., Higgins, D.G. and Gibson, T.J., 1994.** CLUSTAL W: improving the sensitivity of progressive multiple sequence alignment through sequence weighting, position-specific gap penalties and weight matrix choice. *Nucleic Acids Research*, 22, 4673-4680.
- Trench, R.K., 1986.** Dinoflagellates in non-parasitic symbioses. In: *Biology of dinoflagellates* (ed. Taylor FJR). Blackwell, Oxford, pp. 530-570.
- Ulstrup, K.E. and van Oppen, M.J.H., 2003.** Geographic and habitat partitioning of genetically distinct zooxanthellae (*Symbiodinium*) in *Acropora* corals on the Great Barrier Reef. *Molecular Ecology*, 12, 3477-3484.
- Van Oppen, M.J.H., Palastra, F.P., Piquet, A.M.T. and Miller D.J., 2001.** Patterns of coral-dinoflagellate associations in *Acropora*: significance of local availability and physiology of *Symbiodinium* strains and host-symbiont selectivity. *Proceedings of the Royal Society B: Biological Sciences*, 268, 1759-1767.